

Ultrasonic distance and proximity sensors UPR Series

- Measuring range up to 1000mm
- Slow and fast versions
- Version with 90° (radial) transducer
- Versions with synchronisation input
- Small size M18 x 1
- Measurement independent of material, surface, colour and size of target
- Work under dust, dirt, fog, light
- Detect transparent and bright objects
- Protection class IP 67, fully watertight, robust
- Plastic or stainless steel housing
- Customized versions available!
- Swiss made



Technical specifications		UPR 702	UPR 1002	UPR 1003	UPR 1004
Detection range	mm	0...700	0...1000	0...1000	0...1000
Blind range (no reasonable analogue output signal)	mm	0...160	0...160	0...180	0...180
Adjustment range of binary output (with potentiometer)	mm	160...700	160...1000	180...1000	180...1000
Hysteresis of binary output, axial	mm	40...30	40...30	60...30	70...30
Linearity of analogue output	%FS			<1%	
Over all accuracy in whole temperature range	%FS			~±2	
Operating frequency	kHz			~180	
Status indicator	-			LED red	
Binary output, short circuit proof, max. 0.1A	-			by choice PNP, NPN, NO, NC	
Switching speed max.	Hz	~25	~16	~7	~0.25
t _{on} / t _{off} binary output (depending on potentiometer setting)	ms	<50	<70	<100	<240
Analogue output in detection range (versions)	V	-	(0)...10	(0)...10	(0)...10
R _L min. 10kΩ with V output	V	-	(10)...0V	(10)...0V	(10)...0V
R _L max. 500Ω with mA output	mA	-	(4)...20mA	(4)...20mA	(4)...20mA
Ripple of analogue output	mV	-	~±120	~±100	~±40
Tracking speed of analogue output	s/95%FS	-	<0.1	<0.4	<1.5
Power supply voltage (reversal polarity protection)	VDC			18...33	
Ripple of supply voltage	%			<10	
Mean consumption, switched wo. load	mA	~45	~45	~35	~35
Peak current, switched wo. Load	mA			version with mA output +20mA 300mA/0.1ms	
Temperature coefficient of sensor	mV/°K			typ. +4	
Temperature coefficient of air path	%/°K			-0.17 (increasing temperature → output decreases)	
Ambient temperature during operation	°C			-20...+50	
Sensor temperature during operation	°C			-20...+70	
Pressure range	mbar _{abs}			~900...1100	
Mass wo. Cable	g	~45	~45	~45	~65
Protection class	-			IP67	
Housing material	-	Polyamide	Polyamide	Polyamide	V2A stainless
Electrical connection	-			M8 connector or integrated cable	

Description

Outstanding features of the UPR series are the compact M18 size and the 'W' version with 90° (radial) **SONARANGE** transducer for confine mounting conditions. The sensors are available as pure proximity switches and as distance sensors with V or mA analogue output as well. Typical applications are detection of objects and distance and level measurement.

Model selection

The main difference between the UPR versions is their very different switching speed (measuring speed). Thus the sensor should be selected according to the application as follows.

UPR 702 ...

Very fast, for fast counting and detection of objects up to 700mm distance, binary output only, due to the high speed not to be used in tanks (echo) or applications with a near background wall (secondary echoes)!

UPR 1002 ...

Fast, for fast distance measurement up to 1m, with analogue and binary output, due to the high speed not to be used in tanks (echo) or applications with a near background wall (secondary echoes)!

UPR 1003 ...

Reasonably slow, for general distance and level measurement up to 1m, with analogue and binary output.

UPR 1004 ...

Very slow, for reliable level measurement up to 1m, with analogue and binary output, high sensitivity, in stainless steel housing, transducer surface PTFE coated.

For general applications use model UPR 1003...!

Blind range

The lower detection range is called blind range. It is typical for ultrasonic sensors. In the blind range no distance measurement is possible! However the pure function as proximity switch (binary output) is possible in the blind range with certain restrictions (only bigger objects).

Binary output

The binary output becomes active, i.e. it switches on or off, when a scanned object falls below the set distance or if it exceeds it. Each switch point has a hysteresis (see technical specifications). This is the difference between switch on and

switch off point during approach or departure. Hysteresis is necessary for an appropriate switching behaviour.

The switching distance is set with a 3-turn potentiometer. An object with reasonable size and perpendicularly to the sensor axis is placed at the desired distance from the sensor. First the potentiometer is turned min. 3x counterclockwise to zero (no stop). Then the potentiometer is slowly turned clockwise until the LED illuminates (NO) or expires (NO). Thus the switching distance for the binary output is set.

Synchronisation input (Y versions)

The ultrasonic signals can disturb each other when several sensors are focused on the same target or when sensors are mounted close together. This can be avoided by synchronizing the sending pulses. The synchronisation leads of all sensors are connected to each other by shielded cables as short as possible. Since all sensors send then simultaneously, the current consumption increases heavily. Not used synchronisation leads shall be isolated.

Mounting

Ultrasonic sensors shall be mounted as soft as possible in order to keep acoustic disturbances away from the mounting spot. Thus two M18 nuts, washers and rubber sleeves for mounting are scope of delivery. The rubber sleeves for a hole of $\varnothing 21$ mm shall be used!

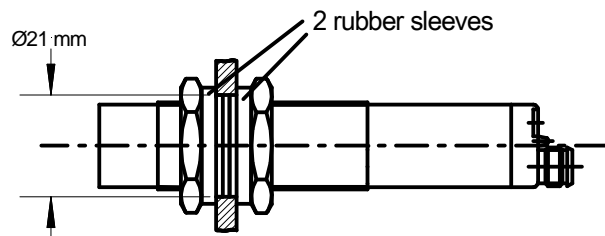

Inclination angle of object

Smooth surfaces can be detected up to an inclination angle of 10°. However rough and structured (granular) surfaces can be detected up to much higher angles.

Cable

The sensors have a 3- or 4-pin M8 connector for screw or snap-on connection or an integrated cable. The cable should be kept as short as possible. Maximum cable length is approx. 100m, if cross section area is appropriate (peak current of 300mA!, use 470µF/35V backup capacitor close to sensor). The cable should not be mounted parallel or close to high current cables.

Cables for connection to the M8 connector have to be ordered separately.

Power supply

Ideally a power supply is used exclusively for the sensor. The power supply must be able supply the short peak current of approx. 300mA for each sensor. In order to avoid disturbances the part where the sensor is mounted must be correctly earthed.

Detection beam

The detection beam of an ultrasonic sensor has the shape of a cone. The size depends on the target and its sound reflecting characteristics. Small and more badly reflecting objects result in a smaller cone (narrower and shorter). Bigger objects and those with surfaces which are not perpendicular to the central axis can expand the cone. The exact cone shape and size can be determined only at the object itself. No disturbing objects must be between the sensor and the target within the cone. Otherwise the sensor would detect the disturbing object instead of the desired target. Below the typical cone shapes for the UPR sensors are shown. The bold line shows the range, where the sensor detects objects which are perpendicular to the sensor axis. In the dotted range the sensor detects round objects (Ø10mm). Furthermore the size of the detection beam is influenced by air temperature and humidity. The colder and dryer the air, the larger is the beam.

No other ultrasonic sensor working at the same frequency shall be within the cone or close to it or opposite to it. This is only allowed when using the synchronisation option (Y-version).

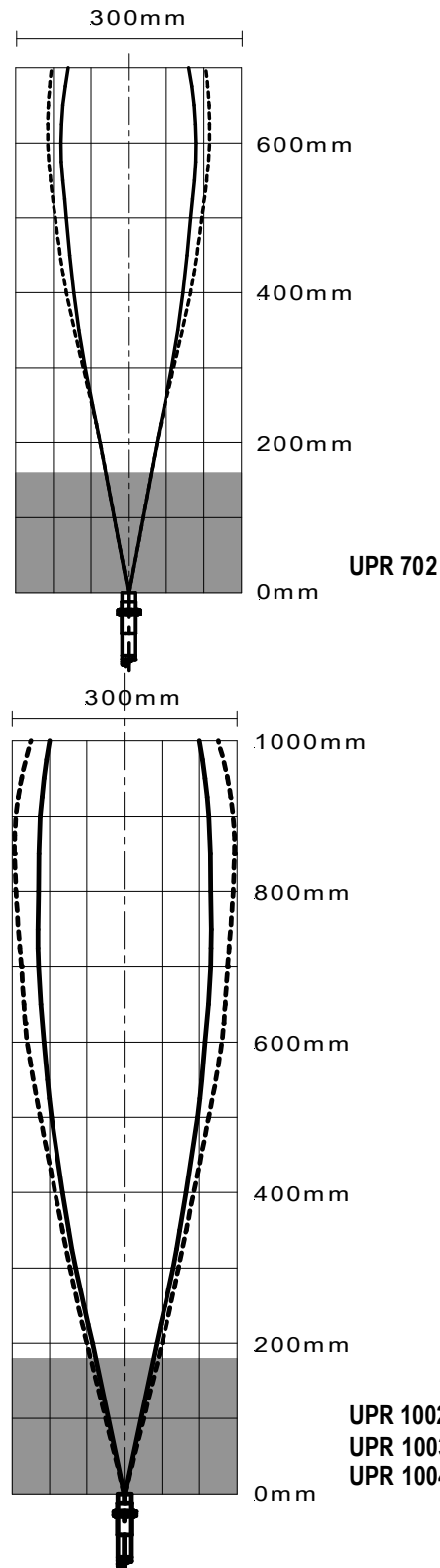

Standard versions

Type	Description	Scheme
UPR 702 PS 24	axial transducer, PNP NO, 2m integrated cable	A
UPR 702 PS 24 W	radial transducer, PNP NO, 2m integrated cable	A
UPR 100X PS 24	axial transducer, PNP NO, 2m integrated cable	A
UPR 100X PS 24 W	radial transducer, PNP NO, 2m integrated cable	A
UPR 100X PS 24 A	axial transducer, PNP NO, analogue output 0...10V, 4-Pin connector	B
UPR 100X PS 24 WA	radial transducer, PNP NO, analogue output 0...10V, 4-Pin connector	B
UPR 100X PS 24 VA	axial transducer, PNP NO, inverted analogue output 10...0V, 4-Pin connector	B
UPR 100X PS 24 VWA	radial transducer, PNP NO, inverted analogue output 10...0V, 4-Pin connector	B
UPR 100X PS 24 I	axial transducer, PNP NO, analogue output 4...20mA, 4-Pin connector	B
UPR 100X PS 24 WI	radial transducer, PNP NO, analogue output 4...20mA, 4-Pin connector	B
UPR 100X PS 24 Y	axial transducer, PNP NO, Synchronisation input, 4-Pin connector	C
UPR 100X PS 24 WY	radial transducer, PNP NO, Synchronisation input, 4-Pin connector	C
UPR 100X PS 24 C	axial transducer, PNP NO, 3-Pin connector	A
UPR 100X PS 24 CW	radial transducer, PNP NO, 3-Pin connector	A
UPR 100X	UPR 1002 ... = switching speed 16Hz UPR 1003 ... = switching speed 7Hz (this version shall be used for standard applications!)	
UPR 1004 PS 24 RA	stainless steel housing, axial transducer, PNP NO, analogue output 0...10V, 4-Pin connector	B
UPR 1004 PS 24 RVA	stainless steel housing, axial transducer, PNP NO, analogue output 10...0V, 4-Pin connector	B
UPR 1004 PS 24 RI	stainless steel housing, axial transducer, PNP NO, analogue output 4...20mA, 4-Pin connector	B
Option	NPN instead of PNP	
Option	NC instead of NO	

Basically almost all possible versions are available according to the following product key:

Product key

UPR XXXX □ □ 24 □ □ □ □

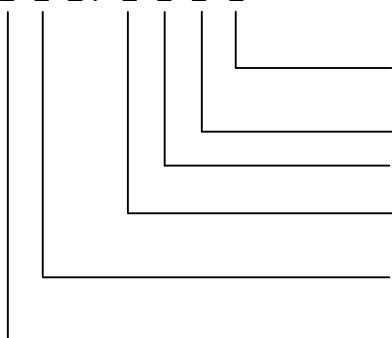

Synchronisation input	Y
Analogue output 10V	A
Analogue output 20mA	I
90° radial transducer	W
Inverted analogue output	V
3-Pin connector (only binary output)	C
Integr. cable (only binary output)	-
Binary output (NO)	S
Binary output (NC)	O
Binary output PNP	P
Binary output NPN	N

Accessories (see also data sheet ,ACC')

Cables 4-pin with M8 screw connector, PUR:

with straight connector: l=2m Type KAB 2K4VGPUR
 l=5m Type KAB 5K4VGPUR
 with 90° connector: l=2m Type KAB 2K4VWPUR
 l=5m Type KAB 5K4VWPUR

Cables 3-pin with M8 screw connector, PUR:

with straight connector: l=2m Type KAB 2K3VGPUR
 l=5m Type KAB 5K3VGPUR
 with 90° connector: l=2m Type KAB 2K3VWPUR
 l=5m Type KAB 5K3VWPUR

Diagrams of connections

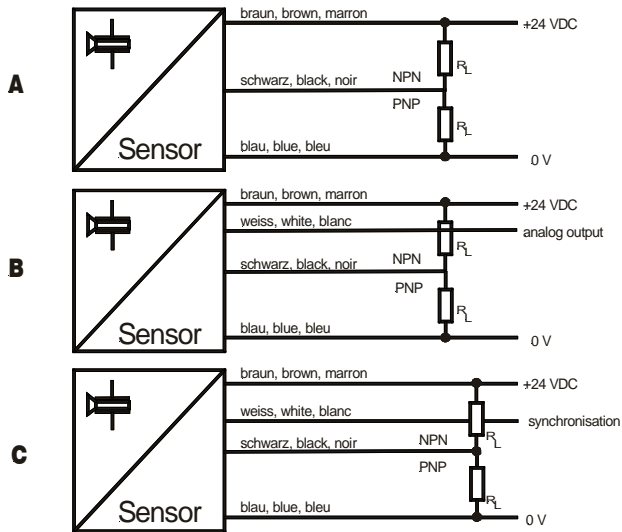

Dimensions

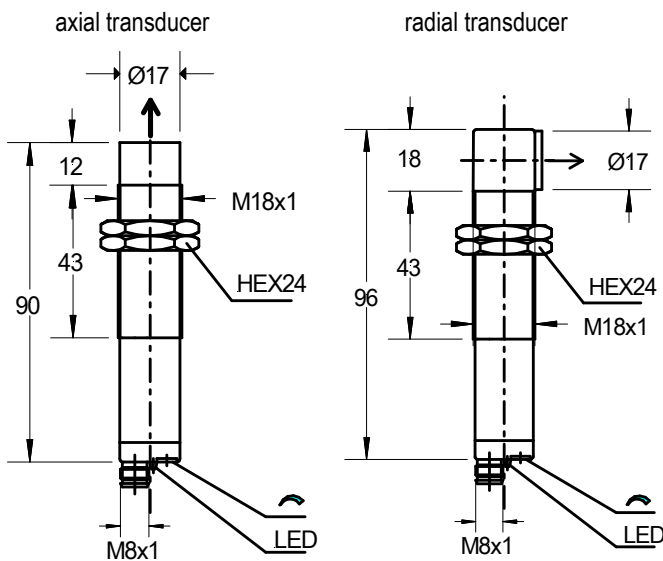

Use an appropriate miniature screw driver max. size 2.5mm for adjustment of the potentiometer for switching distance!

Scope of delivery

- Sensor
- 2 of each M18 nuts, washers and rubber sleeves for mounting

Some typical ultrasound applications

Level measurement

- Measuring level in small containers
- Water gauge measurement
- Monitoring liquid levels in bottling plants
- Checking for tailbacks on conveyor belts
- Monitoring contents of granulate hoppers on injection molding machines
- Distance monitoring on combine harvesters, beet lifters etc.
- Monitoring ground clearance and distance on agriculture and construction vehicles

Process control

- Controlling belt tension or sag
- Sensing and signaling valve positions
- Measuring roll diameter on reeling machines
- Monitoring the height of stacks (charges, storehouse, assembling machines)
- Detecting material feed
- Detecting the feed of strip stock to blanking machines and presses
- Detecting on plastic blow-molding machines

Counting / Detection

- Counting onlookers at freestanding sales displays or show cases
- Access supervision at rotating doors, counters etc.
- Door automation
- Detecting transparent objects, foils, flat glass, bottles etc.
- Sensing objects in robot grippers
- Recognizing full or empty pallets
- Count and detect objects with 'difficult' surface
- Detect wrong parts on conveyors
- Collision protection on vehicles

Scanning of dimensions

- Determining the dimensions of packages
- Sensing the height of plants in automated green houses
- Measuring the volume of tree-trunks