

## Ultrasonic Through Beam Sensor UPB Series

- Large detection range up to 2500mm
- Small size in popular 'R-Shape'
- Microprocessor controlled
- No blind range
- Very high switching frequency (200Hz)
- For detection of fast objects and objects with small distance to each other
- For detection of non right-angled surfaces
- Adjustable transmitter power
- Adjustable switching delay
- Works under dust, dirt, fog, bright light
- Detects transparent and bright objects
- Watertight, IP 67, oil resistant, robust
- Swiss made



download data sheet on  
your smart phone with  
a QR-Code scanner app.



## New: Version 2500mm

### Technical specifications

### UPB 1500 or UPB 2500

Detection range	mm	0...1500 / 0...2500
Operating frequency	kHz	~180
Status indicator transmitter	-	LED green
Status indicator receiver	-	LED yellow
Switch output, short circuit proof, max. 0.1A	-	by choice PNP, NPN, NO, NC
Switching frequency	Hz	200
Sampling frequency	Hz	800
t <sub>on</sub> switch output (adjustable on receiver with potentiometer)	ms	3...~400
t <sub>off</sub> switch output	ms	<3
Transmitting power (adjustable on transmitter with potentiometer)	%	~0.5...100
Power supply voltage (polarity reversal protection)	VDC	18...30
Ripple of supply voltage	%	10
Mean consumption transmitter		
@ max. transmitter power	mA	35
@ min. transmitter power	mA	10
Peak consumption transmitter		
@ max. transmitter power	mA	55
@ min. transmitter power	mA	15
Mean consumption receiver, switched without load	mA	~20
Ambient temperature during operation	°C	0...+50
Sensor temperature during operation	°C	0...+70
Pressure range	mbar <sub>abs</sub>	~900...1100
Mass without cable (transmitter and receiver)	g	45 each
Protection class	-	IP67
Housing material	-	Polyamide and stainless steel
Electrical connection	-	3-pin connector 8mm

[www.sntag.ch](http://www.sntag.ch)

This Information corresponds to the current state of knowledge. SNT reserves the right to make technical changes. Do not use these products in any application where failure of the product could result in personal injury. Liability for consequential damage resulting from the use of SNT products is excluded.

SNT Sensortechnik AG, Hammerstrasse 6, CH-8180 Bülach, Switzerland, Phone +41 44 817 29 22, Fax +41 44 817 10 83, info@sntag.ch

## Properties

Ultrasonic sensors are perfectly suited for detection of objects with very different surfaces and under bad environmental conditions (dust, dirt, fog, bright light). A disadvantage is their relatively low measuring speed, caused by the slow speed of sound compared e.g. to the speed of light. Moreover, the so called blind range of ultrasonic scanner type sensors (transmitter and receiver in the same sensor) might be sometimes a disadvantage, too.

Those disadvantages are eliminated with the ultrasonic through beam sensor UPB. In the same way as with a light barrier, the full range between transmitter and receiver can be used. There is no blind range. The measuring speed of 200Hz is very high as well. The microprocessor controlled UPB series combines high acoustic power with small size. This is achieved with new optimized acoustic **SONARANGE** transducers working at high electrical voltages. Thanks to a new transducer sealing the UPB sensors are very robust against many environmental influences. In particular, they are oil resistant, unlike many other ultrasonic sensors. The high measuring speed combined with the large measuring range of up to 2500mm is the outstanding characteristics of the UPB ultrasonic through beam sensor.

## Mounting

Ultrasonic sensors should be mounted softly in order to keep external acoustic noise away from the sensor. The UPB sensors can be mounted in two ways, with two M4 screws through the two holes in the housing or on the M18 thread of the transducer as well. Included as standard are an M18 nut, a washer and a rubber sleeve for mounting on the M18 transducer. The rubber sleeve fits for a mounting hole of  $\varnothing 21\text{mm}$ .

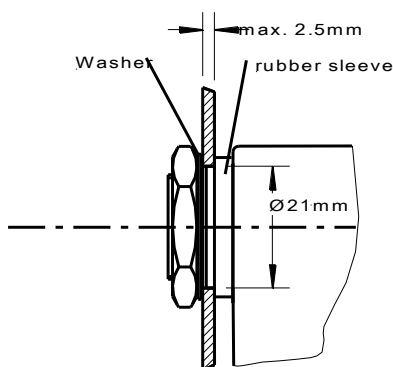

## Cable

Transmitter and receiver have both a 3-pin M8 connector. The cable should be kept as short as possible. The cable should not be mounted parallel or close to high current cables. Cables for connection to the M8 connector have to be ordered separately.

## Power supply

Ideally a power supply is used exclusively for the sensor. In order to avoid disturbances, the part where the sensor is mounted must be correctly earthed.

## Settings

A further outstanding characteristic of the UPB series are the adjustable transmitter and receiver.

### Transmitter (green LED):

The acoustic power can be adjusted with the potentiometer. The max. power (turn clockwise) should be used for big and slow objects and when operating with a large barrier distance. A reduced power (turn counter clockwise) is favorable when the objects are so small, so acoustically transparent or so fast that the sound would go around or penetrate the object with a high power setting. In particular, for small or fast objects the appropriate transmitter power must be experimentally evaluated.

The speed and the width of the object are in the following direct relationship:

$$v \leq \frac{b}{x}$$

v speed of object [m/s]  
b width of object resp. width of the gap between objects [mm] (the smaller is true)

The value x depends on the distance between transmitter and receiver and also on the transmitter power. The min. value of x is 3. With higher distance and higher transmitter power it approaches 30.

### Example:

A 50mm wide object can be safely detected up to a speed of approx. 1.7m/s ( $x=30$ ). With small barrier distance even up to higher speed ( $x=3$ ).

### Receiver (yellow LED):

The switching-on delay can be adjusted on the receiver with a potentiometer. The barrier has max. speed without delay (counter clockwise). This should be the normal operation mode. An increased switching-on delay (clockwise) might make sense when small objects (or disturbances) should not make the sensor to switch.

## Standard versions

Description	Type 1500mm	Type 2500mm
Transmitter, 3-pin connector	UPB 1500 P 24 CT	UPB 2500 P 24 CT
Receiver, PNP, NO, 3-pin connector	UPB 1500 PVPS 24 CR	UPB 2500 PVPS 24 CR
Receiver, NPN, NO, 3-pin connector	UPB 1500 PVNS 24 CR	UPB 2500 PVNS 24 CR
Receiver, PNP, NC, 3-pin connector	UPB 1500 PVPO 24 CR	UPB 2500 PVPO 24 CR
Receiver, NPN, NC, 3-pin connector	UPB 1500 PVNO 24 CR	UPB 2500 PVNO 24 CR

There is a UPB ultrasonic through beam pair of sensors for 1500mm max. distance and one for 2500mm. Transmitter and receiver must not be paired. For an ultrasonic through beam, a transmitter and a receiver have to be ordered separately.

## Detection area

An ultrasonic through beam sensor works according to the principle of shading. As soon as the receiver is sufficiently covered by the object, it switches. The necessary shading for switching can be adjusted with the transmitter power and thus adapted to the object. When several ultrasonic through beams are to be positioned next to each other, each receiver must be outside of the reception range of his neighbor.

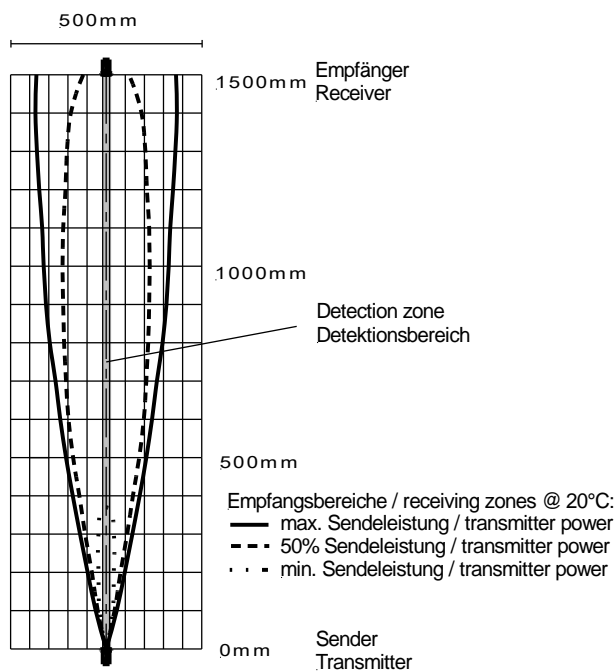

UPB 1500

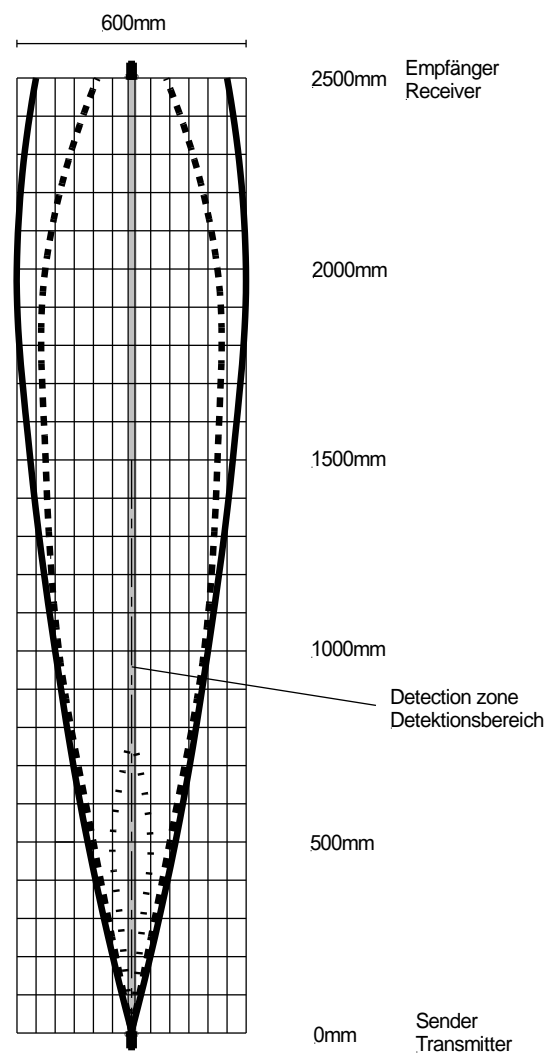

UPB 2500

## Diagrams of connections

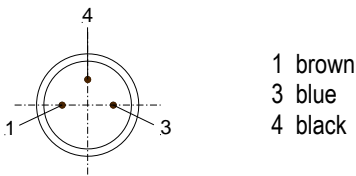
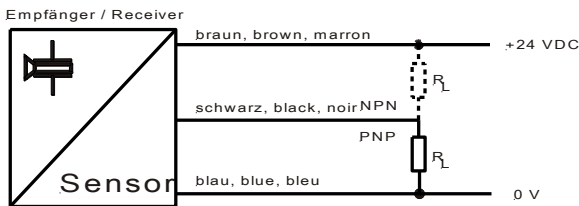

3-pin connector (view on the sensor):

## Dimensions

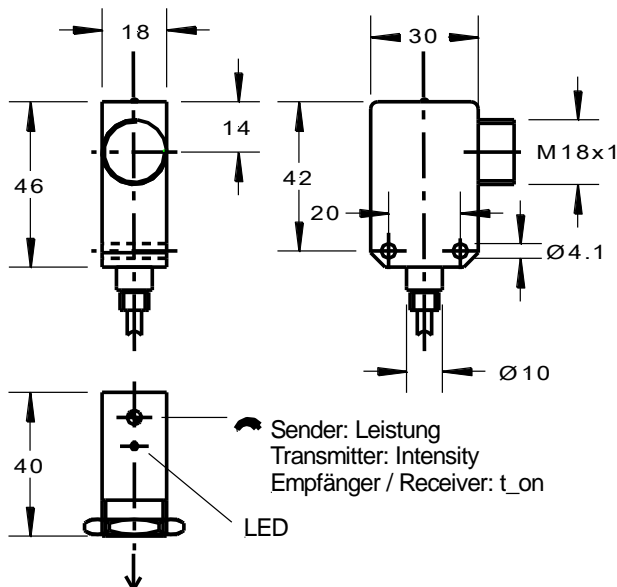

Use an appropriate miniature screw driver max. size 2.5mm for adjustment of the two potentiometers (scope of delivery).

## Included parts

- 1 transmitter or 1 receiver, incl. miniature screw driver
- M18 nuts, washer and rubber sleeve for mounting

## Accessories (see also data sheet („ACC“))

### PUR cable 3-pin with M8 screw connector

- with straight connector: l=2m Type KAB 2K3VGPUR  
l=5m Type KAB 5K3VGPUR  
with 90° connector: l=2m Type KAB 2K3VWPUR  
l=5m Type KAB 5K3VWPUR

## Application hint (picture below)

By means of a hole orifice in front of the receiver (to be machined by the customer), the ultrasound beam can be focused. Thus even smaller objects can easily be detected. This is possible also in dirty environment where optical sensors will fail after short time.

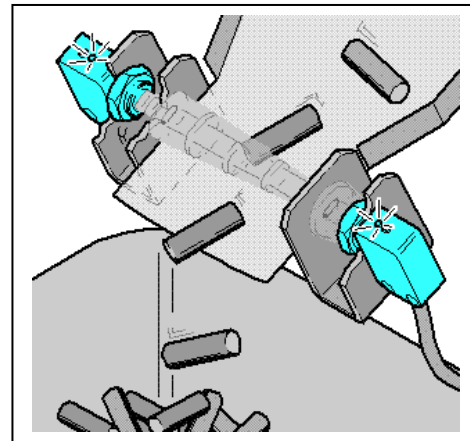

## Some applications for ultrasonic barriers

- Detection of fast objects and those with small mutual distance
- Detection of transparent objects
- Detection of non right-angled surfaces
- Detection of foils, paper etc.
- Level detection in dusty environment

